

**SURVEY-STRATA PLAN**  
**66347**  
SHEET 1 OF 1 SHEET

PLAN OF  
**LOT 403 ON D 39902**

CERTIFICATE OF TITLE  
Volume 1324 Folio 747

LOCAL GOVERNMENT  
CITY OF COCKBURN

INDEX PLAN  
BG34 (2) 08.08  
BG34 (2) 08.09

FIELD BOOK  
120222

SCALE  
1: 300 @ A3

NAME OF SCHEME  
12 BUSHY ROAD  
SPEARWOOD

ADDRESS OF PARCEL  
12 BUSHY ROAD  
SPEARWOOD, W.A., 6163

MANAGEMENT STATEMENT    YES    NO

LODGED	CERTIFIED CORRECT
DATE	COR.
IN ORDER FOR DEALINGS	
FEE PAID	SUBJECT TO
ASSESS No.	
	FOR REGISTRAR OF TITLES    DATE

REGISTERED APPLICATION

DATE    REGISTRAR OF TITLES    SEAL

WESTERN AUSTRALIAN PLANNING COMMISSION  
W.A.P.C. REF: 538 - 12  
Certificate of Approval of W.A.P.C. under Section 25B(2) of Strata Titles Act 1985

Delegated under S.16 P. & D. Act 2005    DATE

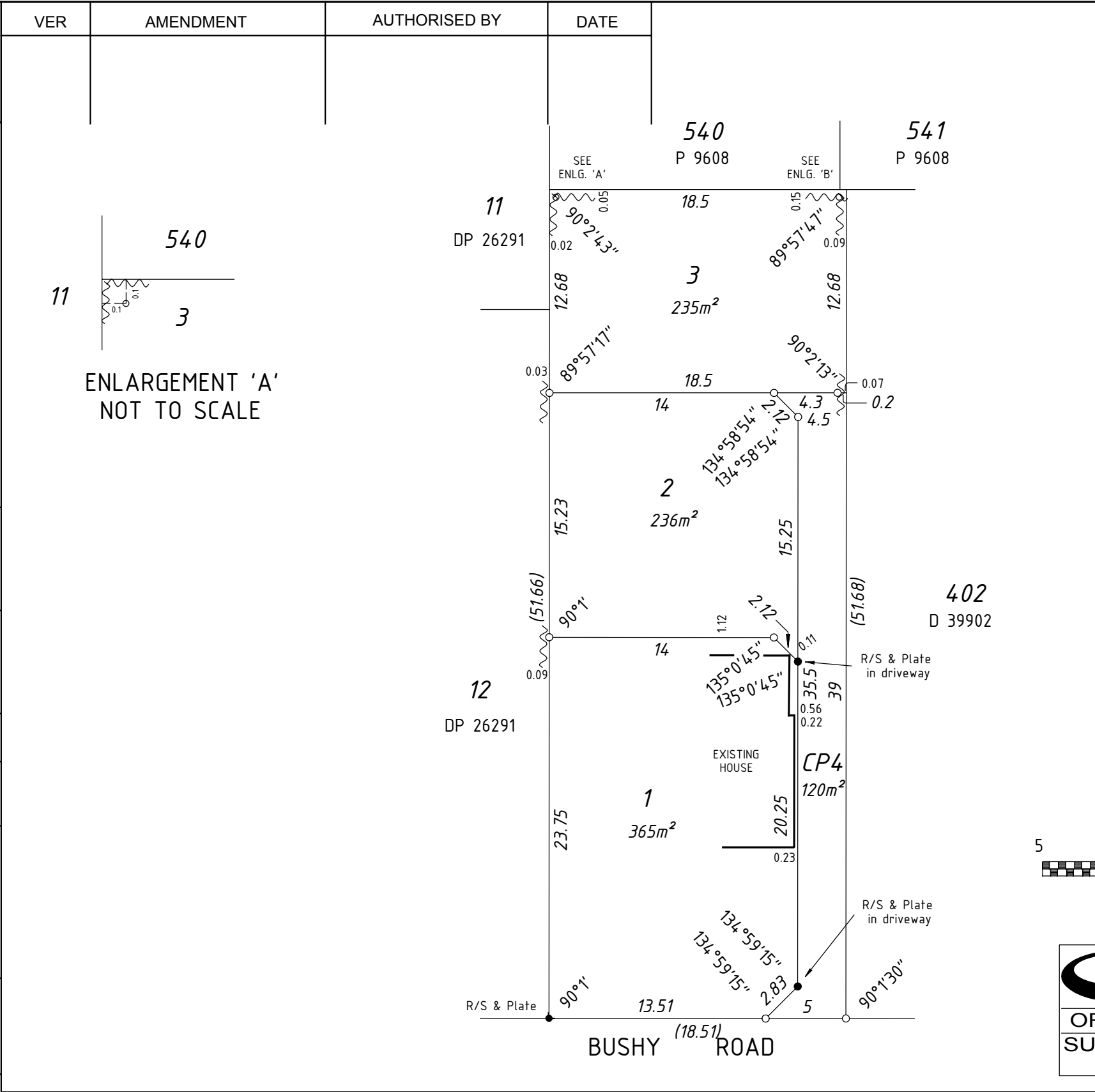

**SURVEYOR'S CERTIFICATE - Reg 54**

I, \_\_\_\_\_  
hereby certify that this plan is accurate and is a correct representation of the -  
(a) \*survey; and  
(b) \*calculations from measurements,  
[\*delete if inapplicable]  
undertaken for the purposes of this plan and that it complies with the relevant written law(s) in relation to which it is lodged.

LICENSED SURVEYOR    DATE

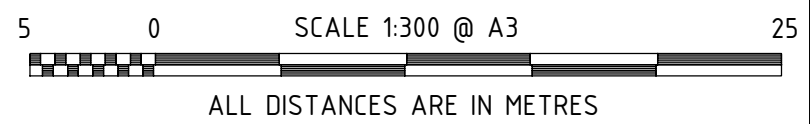
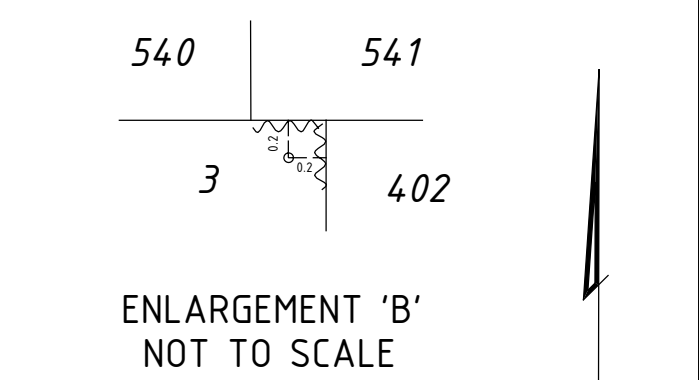

Licensed & Engineering Surveyors  
Land Development Consultants  
Project Managers

TEL 9470 1888 FAX 9470 1333  
PO BOX 668 VICTORIA PARK WA 6979  
email: e@oraclesurveys.com.au

**INTERESTS AND NOTIFICATIONS**

SUBJECT	PURPOSE	STATUTORY REFERENCE	ORIGIN	LAND BURDENED	BENEFIT TO	COMMENTS